



ESA Messtechnik GmbH

Schlossstr. 119 - D-82140 Olching / München
Telefon: +49 (0)8142 444 130 - Fax: +49 (0)8142 444 131
Internet: www.esa-messtechnik.de
E-Mail: info@esa-messtechnik.de

Signal Conditioner Amplifier System *Traveller* CF



Description:

Traveller CF is a Signal Conditioner Amplifier System with CF-Card data Storage. Flexible channel numbers and simple, straight forward operation procedures make the system meet the latest requirements of digital measurement technology and data processing. A built-in PCM-encoder enables telemetric operation with fast data transfer rates and high data security. System Traveller CF excellently satisfies all the sophisticated demands of stationary and mobile measurements of mechanical and electrical quantities.

System Features:

- Low power, low voltage, fully digitalized system
- Arbitrarily selectable and changeable channel identification
- Continuous real-time data transfer with up to 8 MB/sec via USB 2.0 port
- Multiple synchronization of up to 8 system units resulting 512 channels system capacity
- Complete off-line system setup via front plate keyboard
- Real-time data acquisition in hostile environment directly on CF-Card-memory without computer connection.
- Built-in PCM-encoder (IRIG 106) for data transfer as serial data stream (bit rate up to 10 Mbit/sec) for telemetric or cable operation
- As an option, the USB-Interface can be replaced by an Ethernet-Interface for the entire system operation and data acquisition. This enables the system to be operated within a Local Area Network or within the Internet. In this operation mode Traveller CF works as the FTP-Server.

Technical Specification (Basic System Unit):

Housing:	For 16, 32 and 64 channels systems with LCD-display and front plate keyboard
Number of Channels:	8 analog channels per analog board (up to 2, 4 or 8 boards per system)
Data Acquisition:	Simultaneous data acquisition sampling process of all channels in system
A/D-Converter:	16 bit A/D-converter for each analog channel; range ± 2.500 VDC; programmable sampling rate of 0.007 up to 100,000 samples per second per channel
Filter:	Digital hardware filter for each channel (noise reduction)
Interface:	USB 2.0 interface (compatible with USB 1.1) for data transfer and setup commands to or from PC (USB Mode)
Additional Interface:	RS232 interface for connection of event marker AT-Mark-2 or RCU (Remote Control Unit), Ethernet (Option), Synchronization (Option), PCM (Option)
Data Storage and Data Readout:	Data stream can be stored on CF card memory inserted in system slot; sampling rate with continuous writing of data to CF card max. 600 kS/s. Data at CF card can also be transferred to PC through special PCMCIA or USB-adapter. PC will identify the CF card as regular data storage device. WINDOWS® compatible file system implemented on the system's CF cards. CF card storage space up to 2 GB. Optionally, CF cards can be replaced by standard HDD's (Opt. HDD)
Trigger:	Analog signal – rising edge (programmable level and duration); analog signal – falling edge (programmable level and duration); analog signal - level (programmable level and duration); programmable start and stop time (year, month, hour, min., sec.)
Power Supply:	10 to 36 VDC
Size and Weight	81 mm x 302 mm x 206 mm; 2,2 kg – for 16 channels system cabinet 121 mm x 302 mm x 206 mm; 3,5 kg – for 32 channels system cabinet 202 mm x 302 mm x 206 mm; 6 kg – for 64 channels system cabinet

Plug-in Board Features:

- Separate, programmable 16 bit A/D-converter for each channel
- Integrated, programmable 0 to 8 VDC excitation voltage supply for connected sensors
- Permissible current of excitation power supply 320 mA max. with overload protection
- Integrated bridge completion resistors for strain gauge applications
- Integrated, programmable low-pass filter up to 25000 Hz
- ± 5 V analog output for each channel (short circuit proof)
- Digital inputs for various digital signals and digital sensors
- Inputs for analog signals up to 40 V

Technical Specifications Strain Gauge Input Board Mod. SGA-1D:

Number of Channels:	8 complete signal conditioner amplifier channels per board
Input:	120 Ω , 350 Ω strain gauge quarter bridges, 50 Ω to 5000 Ω strain gauge half- and full bridges and strain gauge based transducers; 1000 Ω strain gauge quarter bridges (option); Piezo-resistive transducers for various quantities; potentiometers; voltages of up to 40 V through HVIA-adapter (Option).
Input Voltage:	$\pm 2,5$ V
Input Overload Voltage Protection:	± 30 V
Input Impedance:	20 M Ω , 1500 pF
Signal Bandwidth:	0 to 10 kHz at all gains (without fixed low-pass-filter)
Bridge Excitation:	Software adjustable DC bridge excitation, common for all channels
Range:	0 to 7,0 VDC max. in steps of 2,5 mV
Current:	320 mA max. per board with overload protection (40 mA per channel)

Measurement Range:	
Gain 1; 2; 4 and 8:	Input voltage range: $\pm 2,5$ V; $\pm 1,25$ V; $\pm 0,625$ V; $\pm 0,375$ V
Gain 50:	$\pm 20\,000$ $\mu\text{m/m}$ at bridge excitation 5 V and gauge factor 2,00 Input voltage range: ± 50 mV
Gain 100:	$\pm 10\,000$ $\mu\text{m/m}$ at bridge excitation 5 V and gauge factor 2,00 Input voltage range: ± 25 mV
Gain 200:	$\pm 5\,000$ $\mu\text{m/m}$ at bridge excitation 5 V and gauge factor 2,00 Input voltage range: $\pm 12,5$ mV
Gain 400:	$\pm 2\,500$ $\mu\text{m/m}$ at bridge excitation 5 V and gauge factor 2,00 Input voltage range: $\pm 6,25$ mV
Balance Range:	$\pm 100\%$ of measurement range, 16 Bit resolution
Required Balance Time:	10 s, independent of number of channels
Calibration:	Software controlled shunt calibration in various configurations; RC1 = 174,65k Ω 0,1 %, 1000 $\mu\text{m/m}$ (0,50 mV/V) for 350 Ω and gauge factor K=2,00, RC2 = 59,88k Ω 0,1 %, 1000 $\mu\text{m/m}$ (0,50 mV/V) for 120 Ω and gauge factor K=2,00, RC3 = 499k Ω 0,1 %, 1000 $\mu\text{m/m}$ (0,50 mV/V) for 1000 Ω and gauge factor K=2,00.
Filter (for each analog channel):	4-Pol Butterworth low-pass filter: Cut-off frequency 5000 Hz (-3dB) (changeable according to user requirements) Digital averaging filter for noise reduction
Analog Output:	± 5 V for each channel

Technical Specifications Strain Gauge Input Board Mod. SGA-2D:

Number of Channels:	8 complete signal conditioner amplifier channels per board
Input:	120 Ω , 350 Ω strain gauge quarter bridges, 50 Ω to 5000 Ω strain gauge half- and full bridges and strain gauge based transducers; 1000 Ω strain gauge quarter bridges (option); Piezo-resistive transducers for various quantities; potentiometers; voltages of up to 40 V through HVIA-adapter (Option).
Input Voltage:	$\pm 2,5$ V
Input Overload Voltage Protection:	± 30 V
Input Impedance:	20 M Ω , 1500 pF
Signal Bandwidth:	0 to 10 kHz at all gains (without fixed low-pass-filter)
Bridge Excitation:	Software adjustable DC bridge excitation, common for all channels
Range:	0 to 7,0 VDC max. in steps of 2,5 mV
Current:	320 mA max. per board with overload protection (40 mA per channel)
Measurement Range:	
Gain 1; 2; 4 and 8:	Input voltage range: $\pm 2,5$ V; $\pm 1,25$ V; $\pm 0,625$ V; $\pm 0,375$ V
Gain 50:	$\pm 20\,000$ $\mu\text{m/m}$ at bridge excitation 5 V and gauge factor 2,00 Input voltage range: ± 50 mV
Gain 100:	$\pm 10\,000$ $\mu\text{m/m}$ at bridge excitation 5 V and gauge factor 2,00 Input voltage range: ± 25 mV
Gain 200:	$\pm 5\,000$ $\mu\text{m/m}$ at bridge excitation 5 V and gauge factor 2,00 Input voltage range: $\pm 12,5$ mV
Gain 400:	$\pm 2\,500$ $\mu\text{m/m}$ at bridge excitation 5 V and gauge factor 2,00 Input voltage range: $\pm 6,25$ mV
Balance Range:	$\pm 100\%$ of measurement range, 16 Bit resolution
Required Balance Time:	10 s, independent of number of channels

Calibration:	Software controlled shunt calibration in various configurations; RC1 = 174,65k Ω 0,1 %, 1000 $\mu\text{m}/\text{m}$ (0,50 mV/V) for 350 Ω and gauge factor K=2,00, RC2 = 59,88k Ω 0,1 %, 1000 $\mu\text{m}/\text{m}$ (0,50 mV/V) for 120 Ω and gauge factor K=2,00, RC3 = 499k Ω 0,1 %, 1000 $\mu\text{m}/\text{m}$ (0,50 mV/V) for 1000 Ω and gauge factor K=2,00.
Filter (for each analog channel):	4-Pol Butterworth low-pass filter: Cut-off frequency 5000 Hz (-3dB) (changeable according to user requirements) Digital averaging filter for noise reduction Low pass DSP-FIR-Filter in 3 steps (depending on sampling rate) with following cut-off frequencies: Step 1: 0,0375 x sampling rate Step 2: 0,1 x sampling rate Step 3: 0,225 x sampling rate
Analog Output:	± 5 V for each channel

Technical Specifications Thermocouple Amplifier Board Mod. TH-1D:

Number of Channels:	8 complete amplifier channels per board
Thermocouple Types:	E, J, K, T, R, S
Measuring Ranges:	E = -100 $^{\circ}\text{C}$ to +1000 $^{\circ}\text{C}$ J = -200 $^{\circ}\text{C}$ to +760 $^{\circ}\text{C}$ K = -150 $^{\circ}\text{C}$ to +1250 $^{\circ}\text{C}$ T = -200 $^{\circ}\text{C}$ to +400 $^{\circ}\text{C}$ R = 0 $^{\circ}\text{C}$ to +1750 $^{\circ}\text{C}$ S = 0 $^{\circ}\text{C}$ to +1750 $^{\circ}\text{C}$
Resolution:	< 0,1 $^{\circ}\text{C}$
Input Impedance:	> 20 M Ω
Temp. Coefficient of Zero:	$\pm 1,2$ $\mu\text{V}/^{\circ}\text{C}$ RTI; 100 $\mu\text{V}/^{\circ}\text{C}$ RT0
Gain:	50, 100, 200, 400
DC Gain Accuracy:	$\pm 0,1\%$ at 20 $^{\circ}\text{C}$
DC Gain Stability:	100ppm/ $^{\circ}\text{C}$
Linearity:	0,02% of Full Scale Range
Common-Mode Rejection:	CMR=100dB for input signal frequency 0 to 10 Hz
Filter:	4-Pol Butterworth low-pass filter, cut-off frequency 10 Hz Digital averaging filter for noise reduction
Analog Output:	± 5 V for each channel

NOTE: The cold junction compensation is common for all channels of a single amplifier board. Consequently, a single board accepts only one type of thermocouple.

Technical Specifications High-level Input Board Mod. HV-1D

Number of Channels:	8 complete input amplifiers per board	
Analog In-puts:	Differential-Input:	± 40 V
	Common Mode Voltage:	± 40 V
Balance:	Type:	Automatic electronically balance circuitry
	Range:	50 % of measuring range
Amplifier:	Ranges:	± 5 V; ± 10 V; ± 20 V; ± 40 V
	Output Filter:	4-Pol Butterworth low-pass filter (- 3 dB): Cut-off frequency 10 Hz to 10 kHz to be specified with order placement Digital averaging filter for noise reduction
	Analog Output:	± 5 V for each channel

Technical Specifications High-level Input Board Mod. HV-2D

	Number of Channels:	8 complete input amplifiers per board
Analog In-puts:	Differential-Input:	± 40 V
	Common Mode Voltage:	± 40 V
Balance:	Type:	Automatic electronically balance circuitry
	Range:	50 % of measuring range
Amplifier:	Ranges:	± 5 V; ± 10 V; ± 20 V; ± 40 V
	Output Filter:	4-Pol Butterworth low-pass filter (- 3 dB): Cut-off frequency 10 Hz to 10 kHz to be specified with order placement Digital averaging filter for noise reduction Low pass DSP-FIR-Filter in 3 steps (depending on sampling rate) with following cut-off frequencies: Step 1: 0,0375 x sampling rate Step 2: 0,1 x sampling rate Step 3: 0,225 x sampling rate
	Analog Output:	± 5 V for each channel

Technical Specifications Strain Gauge Input Board Mod. MAB1 – SG0:

	Number of Input Channels:	8 complete signal conditioner amplifier channels per board
Analog In-puts:	Input Impedance:	20 MΩ at 600 pF
	Configuration:	120 Ω, 350 Ω strain gauge quarter bridges, 50 Ω to 5000 Ω strain gauge half- and full bridges, strain gauge based transducers and voltage sources
	Differential Input Voltage:	± 2,5 V
	Common Mode Voltage:	± 2,5 V
	Input Protection:	Overload proof up to ± 30 VDC
Bridge Excitation:	Range:	0 to 8,0 VDC max. in steps of 2,5 mV individually software adjustable for each channel; 40 mA max. per channel with overload protection
	Accuracy:	0,1 % ± 5 mV
	Temp. Stability:	0,01% /°C
Balance:	Type:	Automatic electronically balance circuitry
	Range:	± 10000 μm/m at excitation voltage 5 VDC and gains 50; 100; 200; and 400 ±100 000 μm/m at excitation voltage 5 VDC and gains 1; 2; 4 and 8
	Balance Time:	10 s , independent of number of channels
Calibration:	Internal Shunt Calibration Resistors:	RC1 = 174,65 kΩ, ± 0,1 %; 1000 μm/m (0,50 mV/V) for 350 Ω and gauge factor 2,00 RC2 = 59,86 kΩ, ± 0,1 %; 1000 μm/m (0,50 mV/V) for 120 Ω and gauge factor 2,00
	Calibration Procedure:	Internally controlled electronic switches for internal, external, unipolar or bipolar calibration
Amplifier:	Gain:	1; 2; 4; 8; 50; 100; 200; 400
	Accuracy:	± 0,2 %
	Temp. Stability:	30 ppm/°C
	Linearity:	0,2 % of full range
	Frequency Response:	DC to 25 kHz at - 3dB
	Slew Rate:	0,5 V/μs
	Noise :	(with 350 Ω source impedance RTI; < 1,5 mV RMS at input frequency of 0,1 Hz to 10 kHz
	Temp. Coefficient of Zero:	± 1μV/°C max.
Common Mode Reduction:	CMR = 80 dB typical for gains 1; 2; 4; 8 CMR = 100 dB typical for gains 50; 100; 200; 400	

Analog Output:	Output:	± 5 V for each channel
	Filter:	5-Pole-Butterworth low-pass filter, software adjustable bandwidths from 10 Hz to 25 kHz (-3 dB). Digital averaging filter for noise reduction Low pass DSP-FIR-Filter in 3 steps (depending on sampling rate) with following cut-off frequencies: Step 1: 0,0375 x sampling rate Step 2: 0,1 x sampling rate Step 3: 0,225 x sampling rate

Technical Specifications High-level Amplifier Input Board Mod. MAB1 - HV0:

Number of Channels:	8 complete signal conditioner channels per board
Measuring Ranges:	± 5, ± 10, ± 20, ± 40 VDC and ±2.5 VDC for potentiometers
Excitation:	in steps of 2,5 mV individually software adjustable for each channel
Range:	0 to 8,0 VDC max.
Current:	40 mA max. per channel with overload protection
Input Impedance:	100 kΩ. For voltage measurements, 10 MΩ for potentiometers
Filter (for each analog channel):	5-Pole-Butterworth low-pass filter, software adjustable bandwidths from 10 Hz to 25 kHz (-3 dB). Digital averaging filter for noise reduction Low pass DSP-FIR-Filter in 3 steps (depending on sampling rate) with following cut-off frequencies: Step 1: 0,0375 x sampling rate Step 2: 0,1 x sampling rate Step 3: 0,225 x sampling rate
Analog Output:	± 5 V for each channel

Technical Specifications Thermocouple Amplifier Board Mod. MAB1 - TH0:

Number of Channels:	8 complete amplifier channels per board
Thermocouple Types:	E, J, K, T, R, S
Measuring Ranges:	E = -100 °C to +1000 °C J = -200 °C to +760 °C K = -150 °C to +1250 °C T = -200 °C to +400 °C R = 0 °C to +1750 °C S = 0 °C to +1750 °C
Resolution:	< 0,1 °C
Input Impedance:	> 20 MΩ
Temp. Coefficient of Zero:	± 1,2 μV /°C RTI; 100μV/°C RT0
Gain:	50, 100, 200, 400
DC Gain Accuracy:	± 0,1% at 20 °C
DC Gain Stability:	100ppm/°C
Linearity:	0,02% of Full Scale Range
Common-Mode Rejection:	CMR=100dB for input signal frequency 0 to 10 Hz
Filter:	5-Pole-Butterworth low-pass filter, bandwidths 10 Hz (-3 dB). Digital averaging filter for noise reduction Low pass DSP-FIR-Filter in 3 steps (depending on sampling rate) with following cut-off frequencies: Step 1: 0,0375 x sampling rate Step 2: 0,1 x sampling rate Step 3: 0,225 x sampling rate
Analog Output:	± 5 V for each channel

Technical Specifications PIEZO-Amplifier Board Mod. MAB1 - PIEZO:

Number of Channels:		8 complete amplifier channels per board
Sensor Types:		Piezoelectric Sensors ICP™- Standard
Input Mode:	Input Coupling:	AC coupling to remove DC bias voltage with high pass response of 0,1 Hz (-3dB). At frequencies below the lower frequency limit, the low frequency attenuation slope is -6dB/octave. DC coupling for measure of sensor output bias voltage
	Range:	±5, ±2,5, ±1,25, ±0,625 V
	Gain:	1, 2, 4, 8
	Constant Current Excitation:	Current source: 3,6 mA ± 0,2 mA
Output Filter:		5-Pole-Butterworth low-pass filter, software adjustable bandwidths from 10 Hz to 25 kHz (-3 dB). Digital averaging filter for noise reduction Low pass DSP-FIR-Filter in 3 steps (depending on sampling rate) with following cut-off frequencies: Step 1: 0,0375 x sampling rate Step 2: 0,1 x sampling rate Step 3: 0,225 x sampling rate
Analog Output:		± 5 V for each channel

Description of Input Board for Digital Signals Mod. CNT-0D:

The CNT-0D Board contains up to 8 digital channels with simultaneous sampling. The data of each digital channel are transferred as single 16 bit words by the ET01 CF System Data Frame. They may represent the physical input values of each of the following modules:

- COUNTER-Module - The module can be programmed for various different operational modes (see description below).
- ON/OFF-Channel-Module (OPTION).
- RS23C-Interface-Module (Option only on request).

The below illustration shows the front plate of the CNT-0D board. The connectors on the CNT-0D board front-plate are arranged as follows:

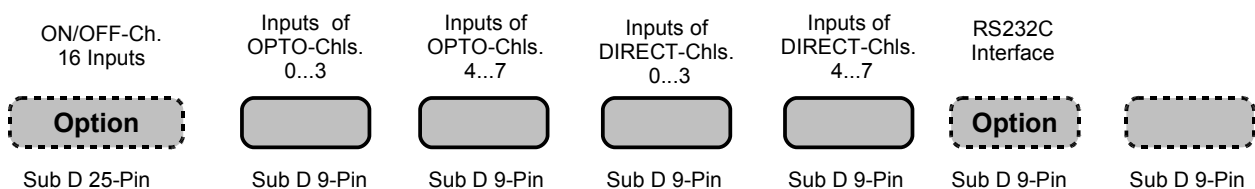

Connector functions (from left to right):

1. Sub D 25 Pin (OPTION): These inputs (not optically insulated) of the 16 digital ON/OFF-channels are compatible with TTL-Standard. The signals are transferred by the ET01 CF System Data Frame as 16 bit words as a single data word. When this channel is operative, it replaces the data of channel no. 0, and has then highest priority.
2. Sub D 9 Pin, OPTO-INPUTS (2 connectors): Optically insulated inputs of 8 digital 16 bit-counter on the CNT-0D board. They have a high input impedance and are compatible with TTL- and LVTTTL-Standard logics. The OPTO-inputs directly drive the Counter modules – description of counter modules see below.
3. Sub D 9 Pin, DIRECT INPUTS (2 plugs): Direct inputs (not optically insulated) of 8 digital 16-bit-counter of the CNT-0D board. They have high input impedance and are compatible with TTL- and LVTTTL-Standard logics. The DIRECT-inputs directly drive the counter modules – description of the counters see below.
4. Sub D 9 Pin, RS232C Interface (option only on request): This input makes full use of the complete RS23C-Interface-Standard. The interface signals are directly transferred to the internal high-perfor-

mance μ -Controller. That allows for the connection each kind of signal source equipped with a RS232C standard output. The data word of this channel replaces the data of channel no. 1 and has highest priority.

IMPRTANT NOTE: The RS232C-Port can be supplied as an option on request and only for know user-owned types of RS232C-sensors!

The following table shows important parameters and Software programmable adjustments of the CNT-0D board's Single-Counter-Module.

Parameter or Mode	Description / Remarks
Counter Input	
Type of Input:	Optically insulated or direct input
Input Impedance:	Optically insulated input: 500 k Ω min. (TTL- and LVTTTL-compatible input)
Direct Input:	Direct input: 500 k Ω (TTL- and LVTTTL-compatible input)
Counter Edge:	Rising or falling edge of input signals
Operational Modes of the Counter	
Counting:	The counter counts the number of events (edges of input signals) after switching on. An automatic RESET to zero will be performed when the number of events reaches 65536.
Timer:	The total number of defined clock periods after the last event is counted in this mode. The counter updates each sample. The internal clock generator of each counter module can be programmed to each frequency between 0.7Hz and 6MHz.
Period:	The defined clock periods between the events are counted in this mode.
Frequency:	The number of events in a defined clock period is counted in this mode.
Synchronization:	The Counter counts the number of events but is asynchronously cleared by the event on the next Counter-Module of the MBA-0 – CNT-0D board. This mode is ideally suited for working with Incremental Sensors.

Other amplifier boards (MAB1 – PT0 for PT-100, MAB1 – LVDT for LVDT-Transducers) are in preparation.

Options for Signal Conditioner Amplifier System *Traveller* CF

PCM-Option for Telemetric Real Time Data Transfer

General Features of PCM ENCODER:

- PCM ENCODER integrated in ET01CF housing.
- PCM-Format : Compatible sub-format to IRIG 106 Telemetry Standard; Bit-Rate: 4.0 Kbits/sec. to 10.0 Mbits/sec .
- PCM Code : Bi-phase Code BIΦ-L (Manchester-Code).
- Data word length : 16 Bits.
- Synchronisation schematic: Two Synchronisation words.
- PCM frame length: 9 to 136 PCM words.
- PCM frame title: 8 Organisation and information words.
- Data range of PCM frame: 1 to 128 data words.
- Data output : LVTTTL-compatible standard.
- Output connector: BNC.

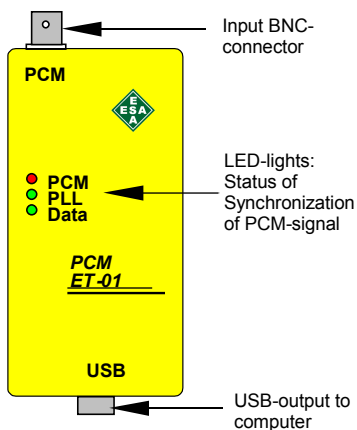
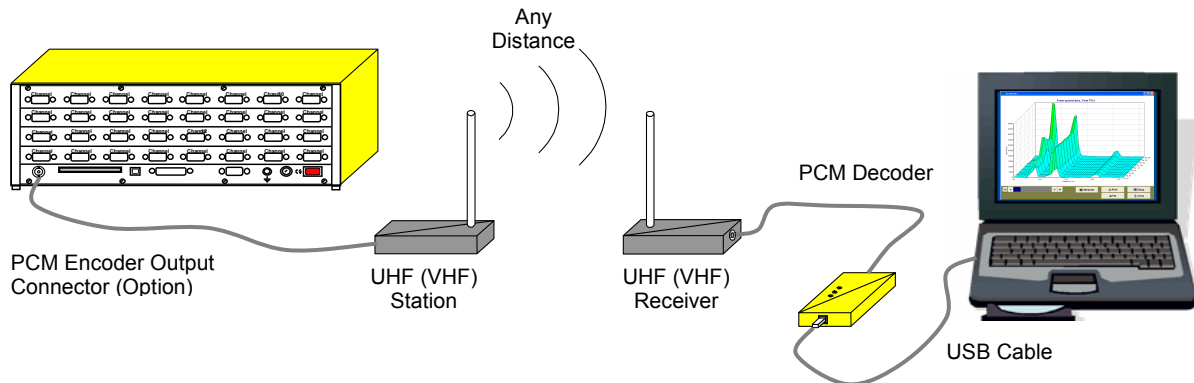

General Features of PCM DECODER

- Very small size : 102 x 56 x 20 mm.
- Input Connector : BNC.
- Input signals : LVTTTL-compatible, accepts cable impedance of 75 Ω
- Power Supply : Powered through USB-Port of PC.
- Data Transfer : Via USB 2.0-Port to PC (up to 8 Mbytes/sec, gapless in real time).
- PLL-Hold-Range: ±6% of medium frequency of received PCM signal-bit-rate.
- Hardware and Software Filter for decoding and Elimination of damaged PCM frames.
- 3 LED-lights for indication of decoder status

Ethernet-Option for Remote-Control

- *Traveller* CF contains a special FTP-server in compliance with standard IEEE 802.3/802.3u for LAN or INTERNET operation.
- Concerning the control functions, there is no operational difference between USB-interface and Ethernet-interface.
- In the special ERK-(Ethernet Remote Keyboard)-mode all *Traveller* CF operational functions are controlled through a virtual keyboard.
- In Internet mode, the special ESAM Software system controls system operation in real time (setup, data monitoring as well as data acquisition on CF-Card or HDD of the remote computer).

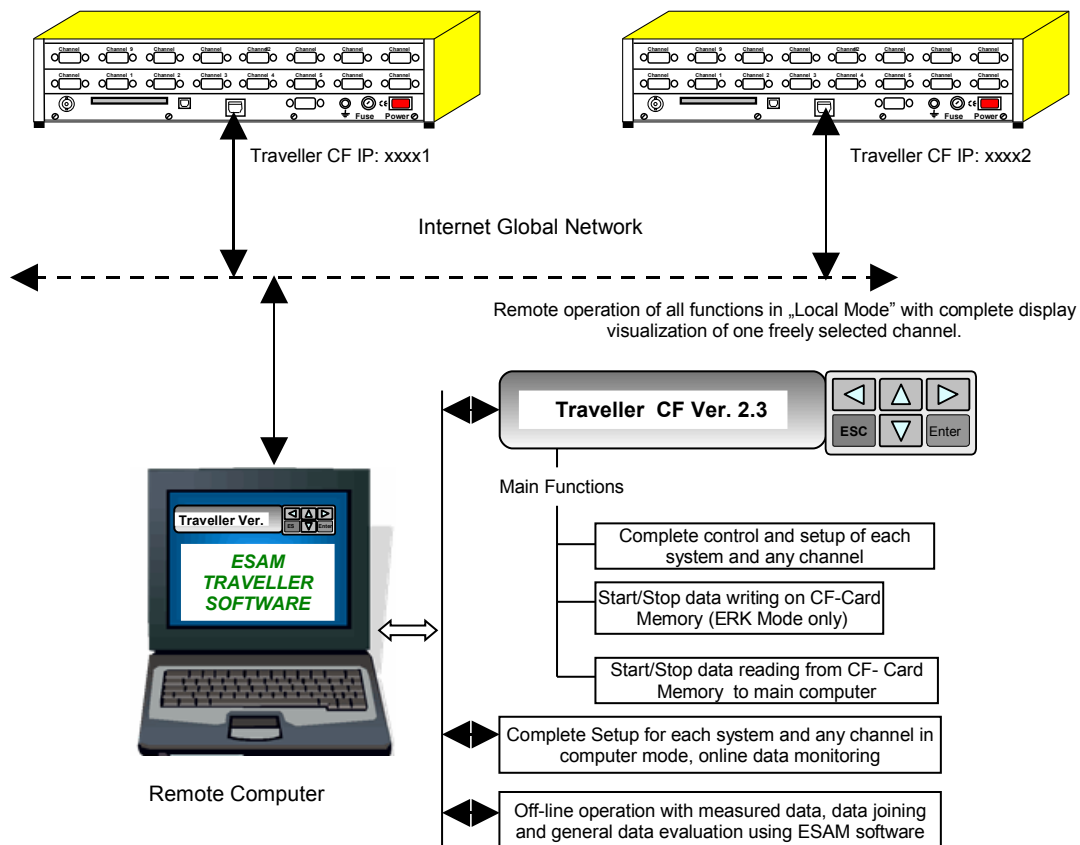

Subject to technical changes and modifications without notice!